

## PAINTING RECOMMENDATION

Like all natural products Taranakipine finger jointed products will react to changes in the climate, including varying moisture and temperature levels. Wood will absorb moisture and expand when exposed to direct contact with water and high humidity and will contract (shrink) when losing moisture.

When preparing for installation it is advisable to apply the 1st topcoat before installation, providing the timber with a level of protection from the elements during the construction process. The final coats should then be applied immediately at the end of installation.

Before Taranakipine products leave our site, they are dried to a moisture content of between 8-15%, primed with an architectural primer and wrapped in a moisture resistant plastic cover. It is very important that all Taranakipine products are kept dry before the topcoats are applied, or if allowed to get wet or gain moisture content through high humidity, that the timber is then allowed to dry and return to a stable moisture content of between 8-15% and the original dimensions BEFORE applying the topcoats.

Correct installation, coating and maintenance will provide many years of pleasure and service.

### DO'S

- Ensure you read the top part of this section first.
- Keep all Taranakipine products DRY.
- Check the moisture content of the board, if this is not possible, check the dimensions of the board. If it is larger than our specification it is likely the board has increased in size due to moisture uptake and should be allowed to dry and return to its normal dimension before installation / painting.
- Seal all end cuts, mitres, notchings, borings, punched nail holes or similar with a suitable cut end preservative (such as Tanalised Enseal Clear) during the construction process, where necessary fill with an exterior grade wood filler, sand back, and prime with a suitable premium exterior wood primer.
- Remove any dirt, dust or other foreign matter from the surface before applying paint.
- If the primed surface has been exposed to elements for some time, the surface can become chalky. If this happens sanding will be required. Ensure any exposed timber is re-sealed using an approved primer before application of the topcoats.
- Apply two coats of a high-quality exterior paint AS PER THE MANUFACTURER'S RECOMMENDATIONS.
- Ensure all necessary personnel are all familiar with these recommendations.
- Always follow the relevant building codes and best practice building methods.

### DON'T'S

- Do not allow Taranakipine products to get wet or be in contact with the ground.
- Do not backfill or place soil, mulch, etc., closer than 150mm to Taranakipine products and ensure adequate ventilation.
- Do not place in direct contact with concrete or masonry.
- Do not install where water sprinklers can regularly wet Taranakipine products.
- Do not install in a manner to allow water to be entrapped behind Taranakipine Weatherboards, Fascia and Reveals.
- Do not use silicon or other sealants as a substitute for flashing.
- Do not install with moisture content over 15%, or paint over wet Taranakipine products.
- Do not install weatherboards directly over wall cavity insulation, ensure a waterproof builder's paper lines the wall before fixing.

**RECOMMENDATION:** Use lighter colours for topcoats. This will reduce the effect of solar energy increasing the temperature of the boards, which may result in adverse weathering of the timber products. We recommend colours with a light reflectance value of 45 or more (where 0 = Black and 100 = White).

**NOTE:** Extreme climates that result in prolonged dry spells and heat, or prolonged wet spells and cooler periods are likely to result in contraction and or expansion of the timber products. This is normal for most building products and should be allowed for when designing the structure and installing Taranakipine products.

## QUALITY PRODUCTS

For the past 60 years Taranakipine products have been marketed and distributed in New Zealand and several international markets including Australia, North America and Europe.

We are proud of the reputation we have established in all these markets for quality products manufactured here in New Zealand.



## OUR BRANDS



[www.taranakipine.co.nz](http://www.taranakipine.co.nz)



[www.bodyguardwood.com](http://www.bodyguardwood.com)



[www.taranakipine.co.nz/products](http://www.taranakipine.co.nz/products)



[www.woodspan.co.nz](http://www.woodspan.co.nz)



## CLADDING Weatherboards and Fascia

FINGER JOINTED FOR STRAIGHTNESS  
LOSP TREATED FOR DURABILITY  
PREMIUM PRIMER COATING  
25 YEAR DURABILITY WARRANTY



**Postal address:** PO Box 7145 Fitzroy, New Plymouth 4341  
**Physical address:** Hudson Rd, Bell Block, New Plymouth

**P:** 06 755 9000 **Fax:** 06 759 4942

**E:** [enquiries@taranakipine.co.nz](mailto:enquiries@taranakipine.co.nz)

[www.taranakipine.co.nz](http://www.taranakipine.co.nz)

TGM1014003

For more about our range of products visit us at

[www.taranakipine.co.nz](http://www.taranakipine.co.nz)

## Weatherboards - 6.1m

Pre-primed and H3.1

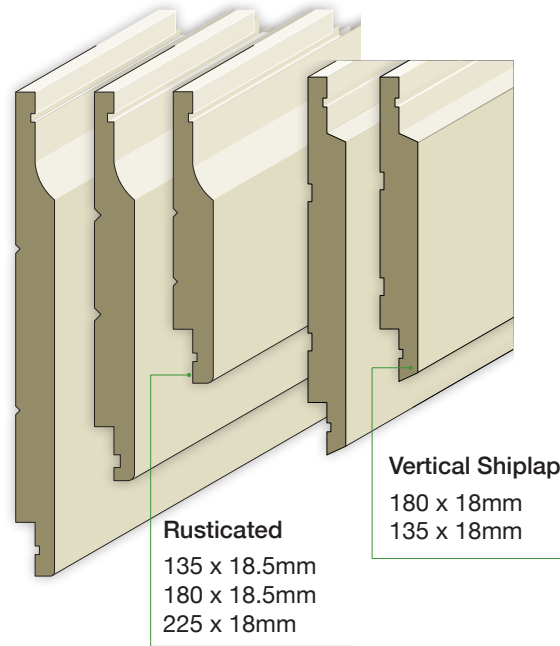
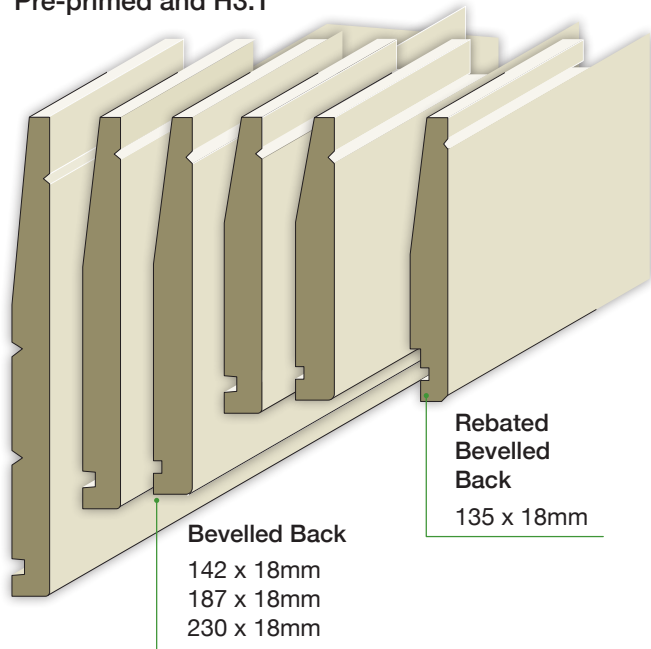

## Fascia - 6.1m

Pre-primed and H3.1

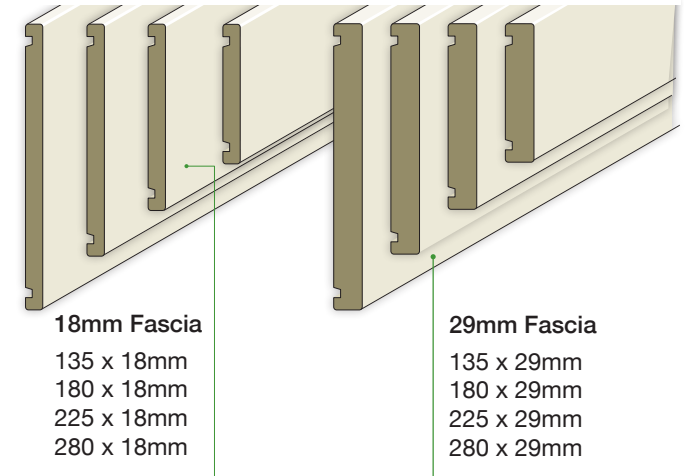

## Solid Weatherboards

Premium grade timber  
Pre-primed and H3.1  
Random lengths



## Weatherboard Accessories - 5.4m

Pre-primed and H3.1

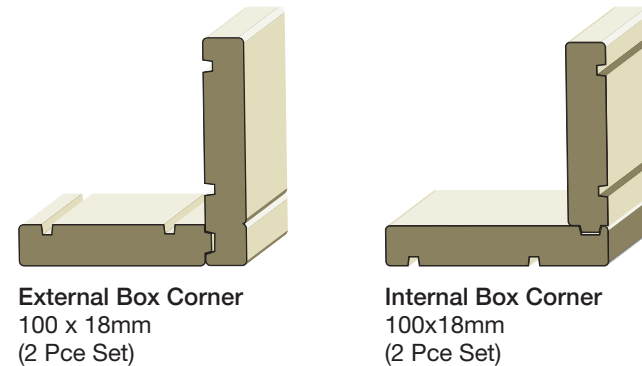

**Cavity Batten**  
44x21mm

\*not pre-primed

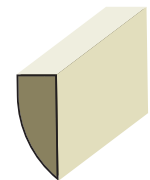

**Rustic Plug**  
100 pcs Bag